

Replacement Parts for Hyster W40Z (B218)

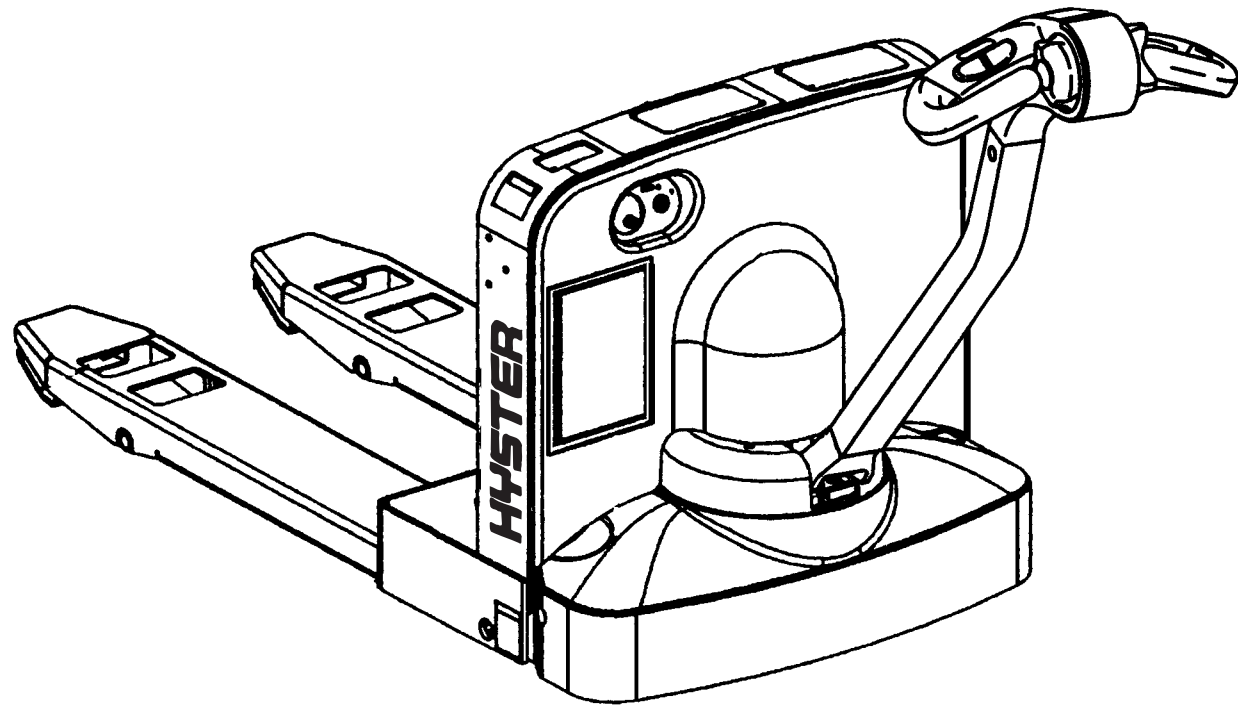

800-462-2370
Fax 800-366-5939
www.SuperStoresService.com



Content

Wheels

Quick Wheel Lookup	4
--------------------	---

Electrical

Battery Tray and Charger	6
Control Panel	8

Drive Unit/Brake

Drive Unit and Brake	10
----------------------	----

Motors

Drive and Pump Motors	12
-----------------------	----

Handle Assembly

Control Arm Assembly	14
Control Handle Assembly	16

Hydraulic

Hydraulic	18
-----------	----

Frame and Undercarriage

Load Wheel and Lift Linkage	20
Caster Assembly	22

Quick Wheel Lookup

Quick Wheel Lookup

OEM #	Wheel Type	Manuf.	Part #	Description	Wheel OD in/mm	Tread Width in/mm	Hub Width in/mm	Hub ID in/mm	Bearing OD in/mm	Bearing #	Material/Color
HY 2046054-A	Load Wheel	Generic	GW 825-A	Poly Load Wheel-Assembly	3.250 / 83	4.500/114	4.500/114		1.547/40	6203z	Scotch, 95-A
HY 2045112	Drive Tire	Superior	SU 9x5x5-SF-P-A	Poly Drive Tire-Incl. Hub	9.00 / 229	5.00/127		5.00/127			Maroon, 91-A
HY 2045107	Drive Tire	Superior	SU 9x5x5-SF-R-A	Rubber Drive Tire-Incl. Hub	9.00 229	5.00/127		5.00/127			Black
HY 2049428	Hub		HY 20492428	Drive Wheel Hub							

HY 2046054-A1
Load Wheel Assembly
w/Bearings and String Guards



HY 800127595
Load Wheel Assembly w/String
Guards and Axle



HY 2045112
Poly Drive Tire w/Hub



HY 2045107
Rubber Drive Tire w/Hub



HY 2043251
Complete Riser and Load Wheel
Assembly



HY 2046054-A1
Load Wheel Assembly
w/Bearings and String Guards



Electrical - Battery Tray and Charger

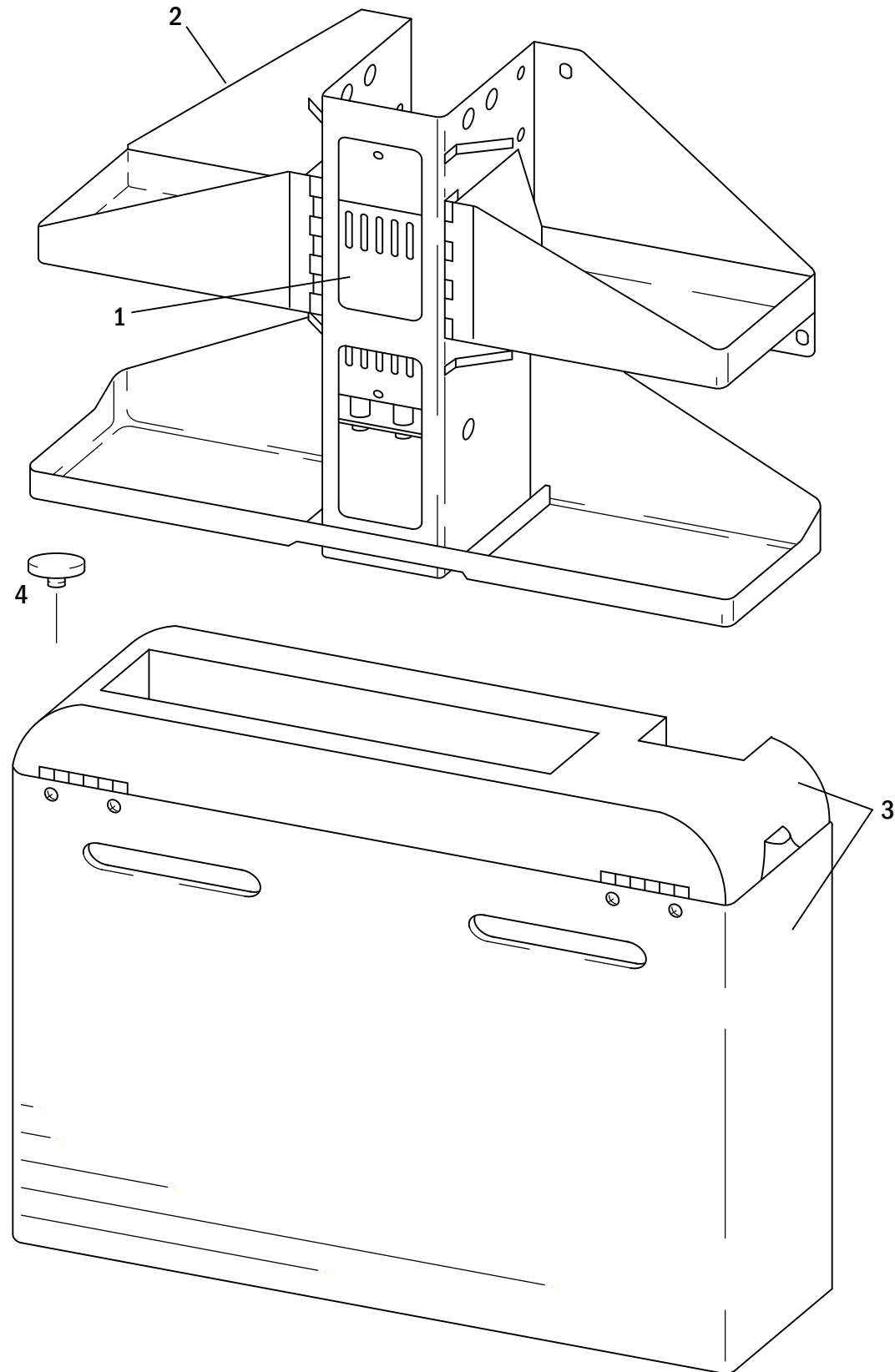

Electrical - Battery Tray and Charger

Item	Part No.	Description
1	HY 2048079	Battery charger, 15A, 120AC \$
2	HY 2048103	Battery Tray assembly
3	HY 1579833	Battery cover and tray assembly
4	HY 2047068	Battery cover knob

Electrical - Control Panel

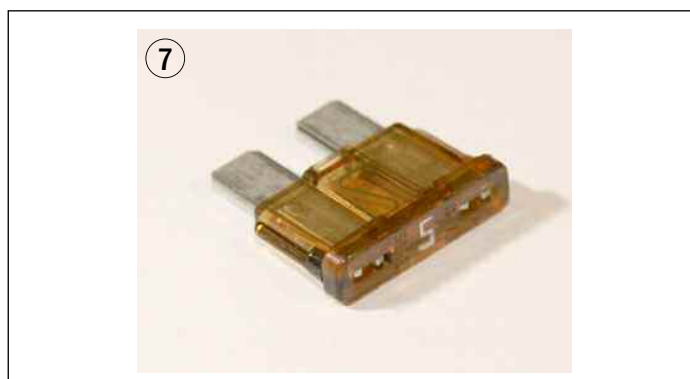

Electrical - Control Panel

Item	Part No.	Description
1	HY 2045946	Red Battery connector, red
2	HY 2045951-R	Controller, renewed
	HY 2045951-C	Core deposit
3	HY 3005833	Ignition switch, w/2 keys
4	HY 262798	Keys, Set of 2
5	HY 2046546	Battery discharge indicator, with MDI
6	HY 354589	Fuse, 150A
	YL 524163968	Fuse, 175 A (not used) (not shown)
7	HY 2046615	Fuse, 5 A
8	HY 2042675	Horn, Safe-T-Alert, 2000 Series, 12-24V dc, 102 DB

Drive Unit and Brake Assembly

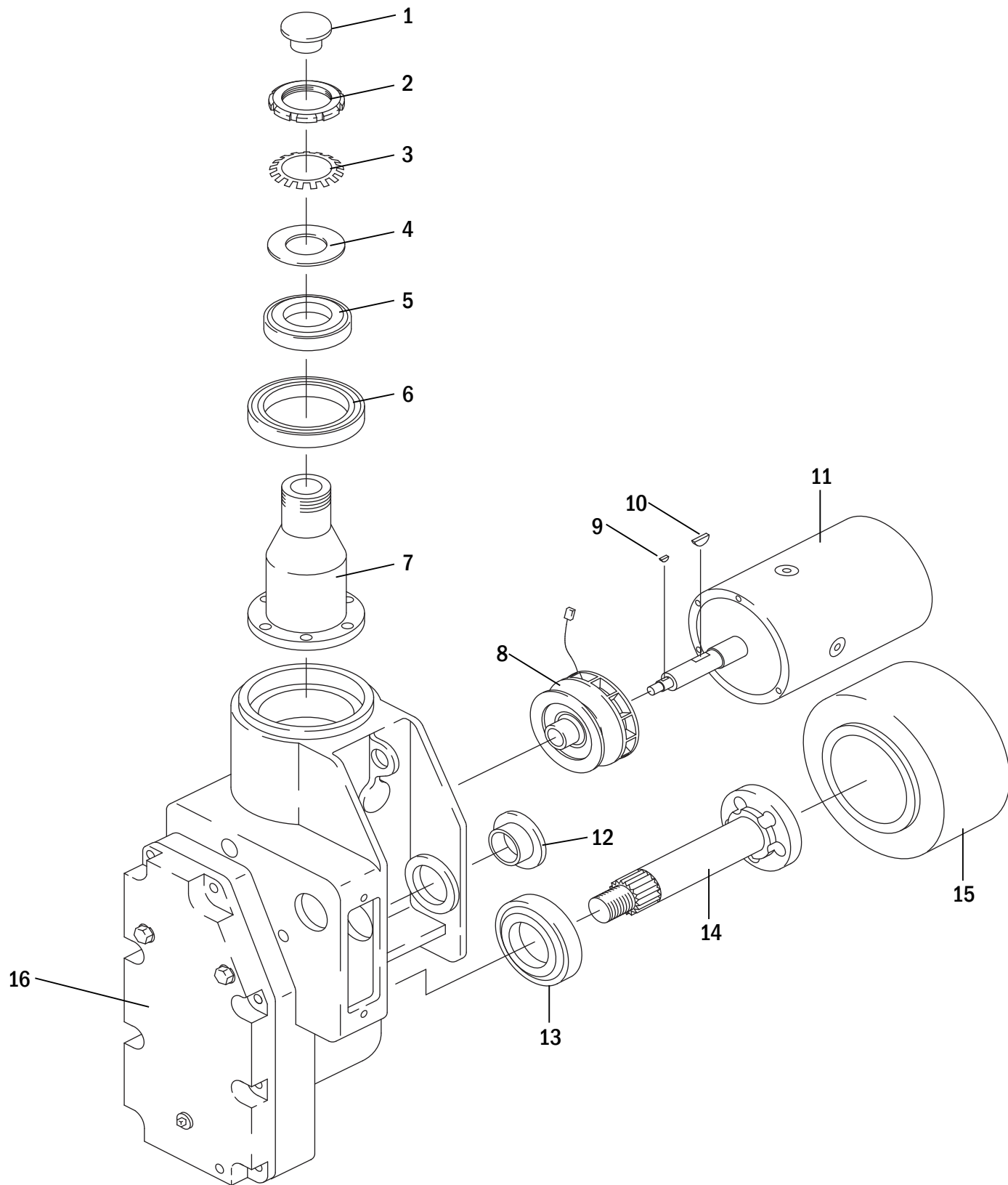

Drive Unit and Brake Assembly

Item	Part No.	Description	Application
1	HY 2307321	Sleeve	
2	HY 2050733	Locknut	
3	HY 2050732	Lockwasher	
4	HY 2048081	Seal	
5	HY 1375474	Tapered bearing	
6	YL 580033251	Bearing cup (not used)	
	HY 163971	Bearing cup	
7	YL 580033250	Bearing cone (not used)	
	HY 174230	Bearing cone	
8	HY 2046003	Brake assembly	
9	HY 2310849	Woodruff key	
10	HY 2051303	Key	
11		See Motor Section	
12	HY 2791987	Bushing	
13	HY 163971	Bearing cup	
	HY 174230	Bearing cone	
14	HY 2304321	Drive axle	
15		See Quick Wheel Lookup pages 4 and 5	
16	HY 1495763	Motor cover	Right hand
	HY 1495764	Motor cover	Left hand

Hyster W40Z

Motors

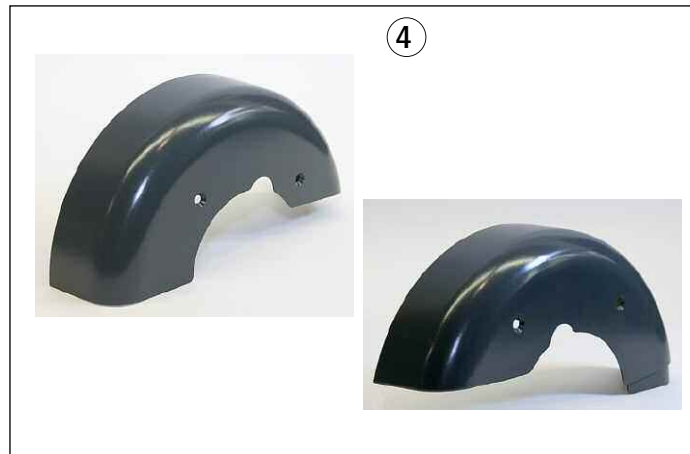

Hyster W40Z

Motors

Item	Part No.	Description
1	HY 2049316-Am	Drive Motor, After-Market
2	HY 1506791-Am	Drive Motor brush set & springs for After-Market Motor
3	HY 1506791	Drive Motor brush set & springs for original motor
4	HY 1495763 HY 1495764	Motor cover, Right hand Motor cover, Left hand
5	HY 1466025-Am	Pump motor, 24V

Handle Assembly - Control Arm

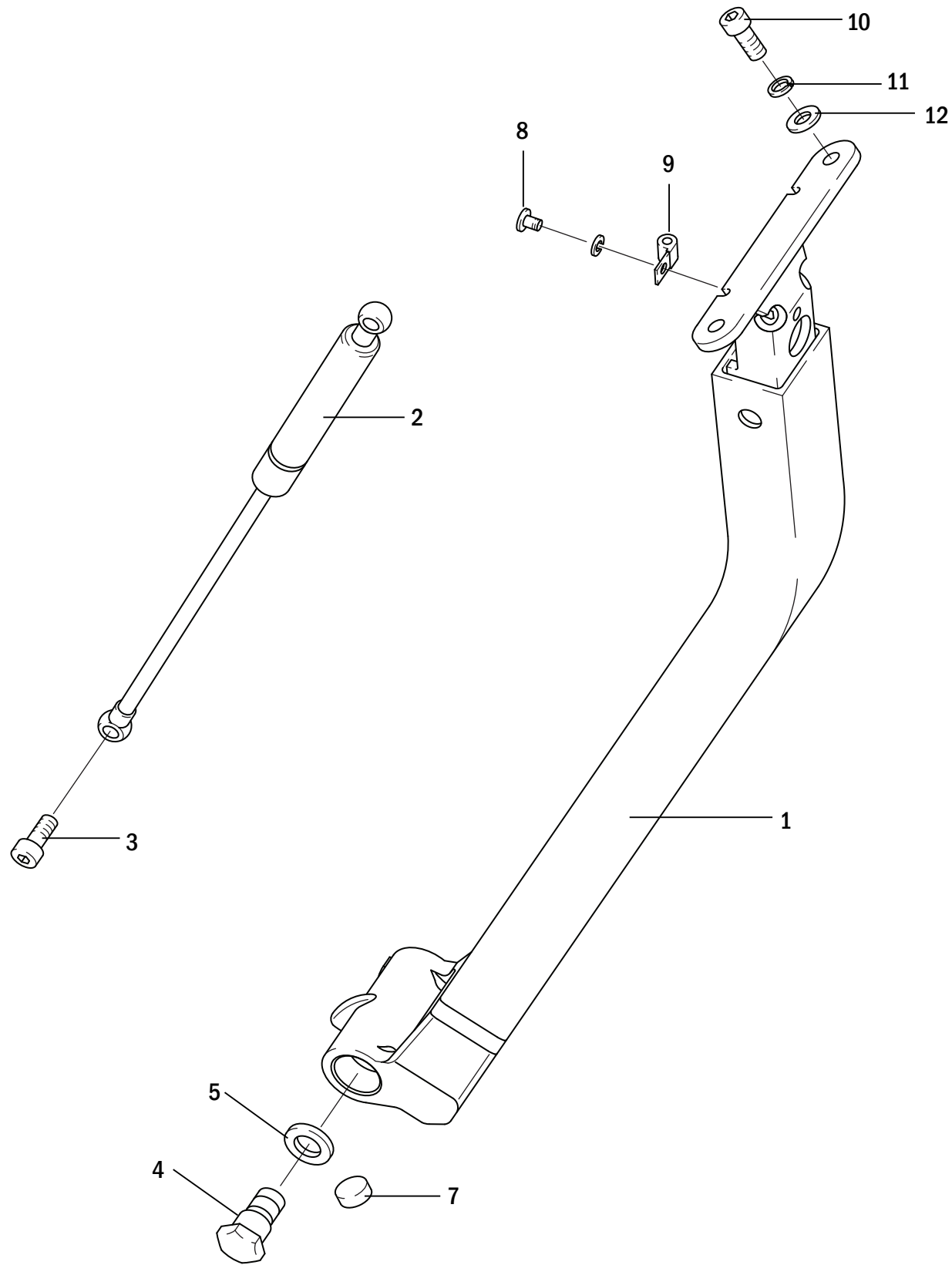

Handle Assembly - Control Arm

Item	Part No.	Description
1	HY 2050082	Steer arm
2	HY 2050083	Gas spring
3	HY 302375	Pin
4	HY 2059695	Steer arm pin, 2 required
5	HY 2791931	Washer
6	HY 2038546	Brake switch w/harness
7	HY 2050084	Bumper, 2 required
8	HY 2792378	Bolt
9	HY 177599	Clamp
10	HY 296166	Cap screw
11	HY 320157	Washer
12	HY 292681	Lockwasher
13	HY 2043856	Cap screw
14	HY 2066432	Control handle wiring harness

Control Handle Assembly

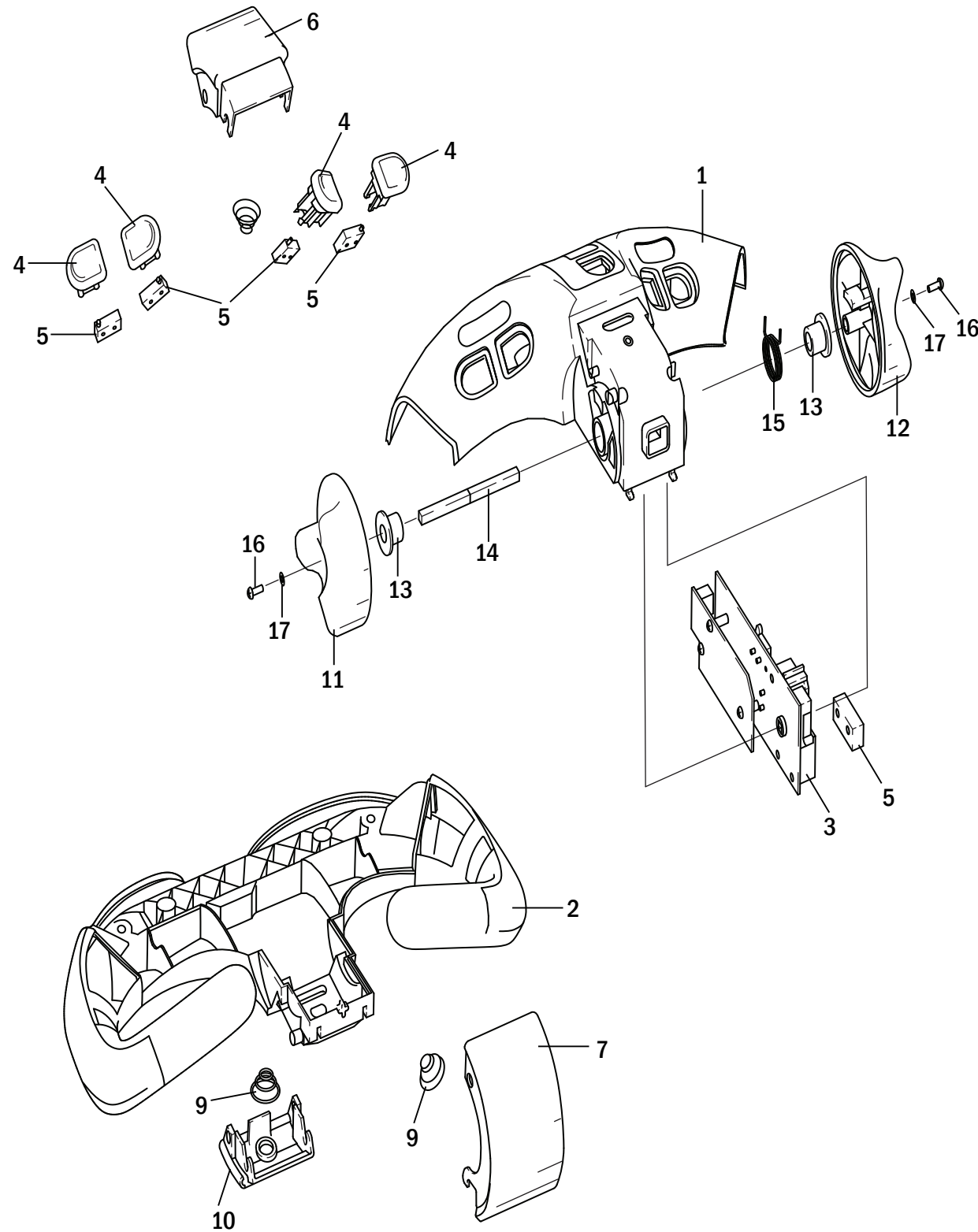

Control Handle Assembly

Item	Part No.	Description
1	HY 2045501	Control handle, upper
2	HY 1467778	Control handle, lower
3	HY 1498100-R	Interface board, Cold storage, Renewed
	HY 1498100-C	Core deposit
4	HY 1466877	Switch assembly
5	HY 1498102	Switch
6	HY 1489471	Horn cover
7	HY 1467779	Switch cover
8	HY 1491262	Switch cover, Turtle option
9	HY 1466606	Spring, Turtle option
10	HY 1467780	Cover
11	HY 1466876	Butterfly switch, Left Hand
12	HY 1466875	Butterfly switch, Right Hand
13	HY 1466595	Bushing
14	HY 1466935	Camshaft
15	HY 1466607	Spring
16	HY 1499660	Screw
17	HY 320152	Washer

Hydraulic Power Unit

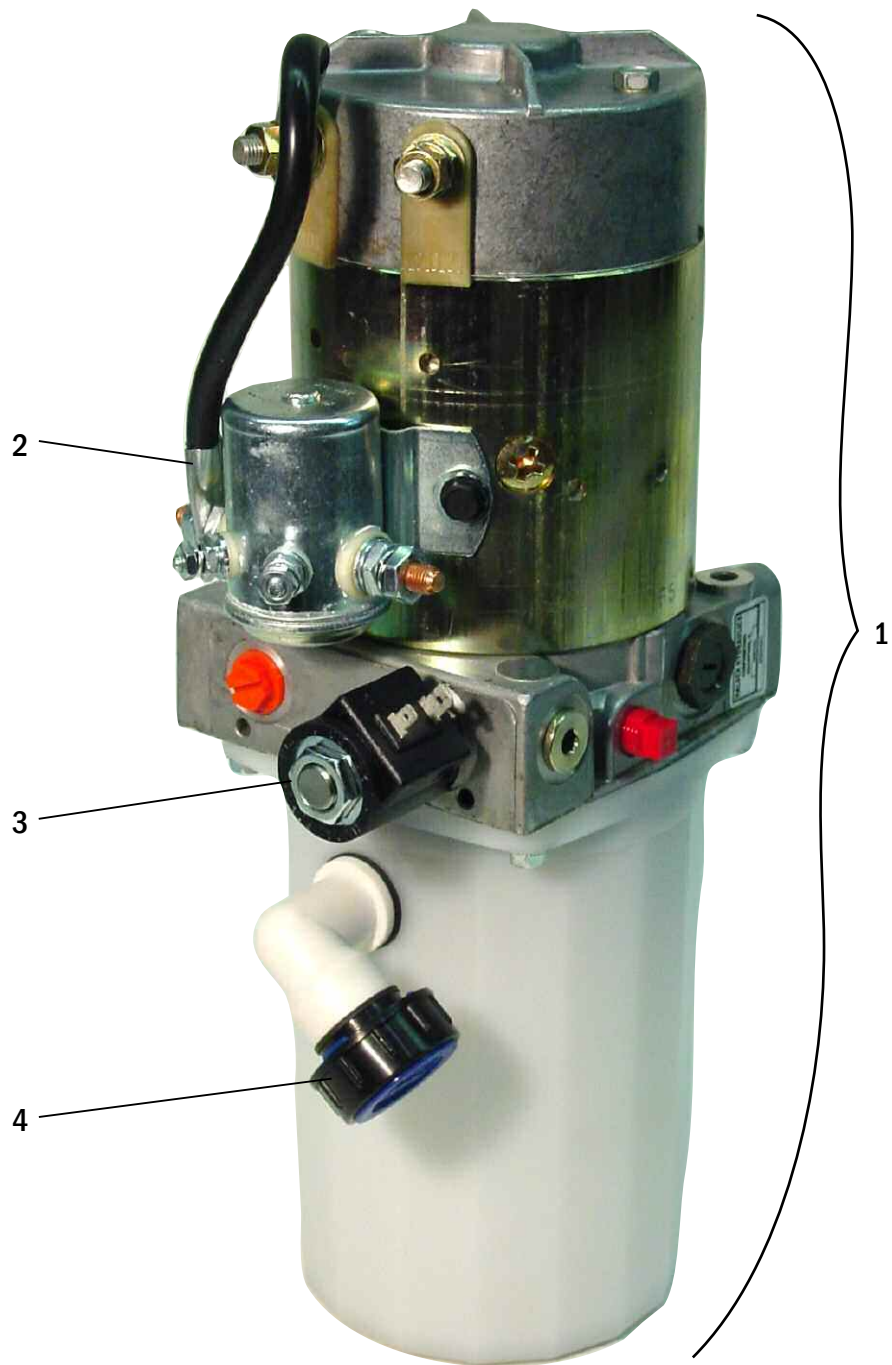

Hydraulic Power Unit

Item	Part No.	Description
1	HY 2046104	Hydraulic power unit
2	HY 1198392	Solenoid
3	HY 1466036	Solenoid valve
4	HY 1474789	Breather
5	HY 2046539	Lift cylinder
6	HY 2048665	Lift cylinder seal kit

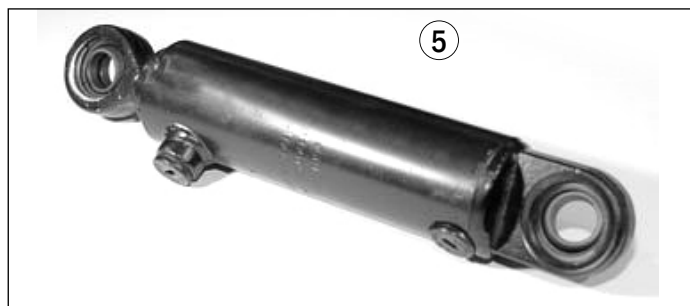

Frame & Undercarriage - Load Wheel & Link Linkage

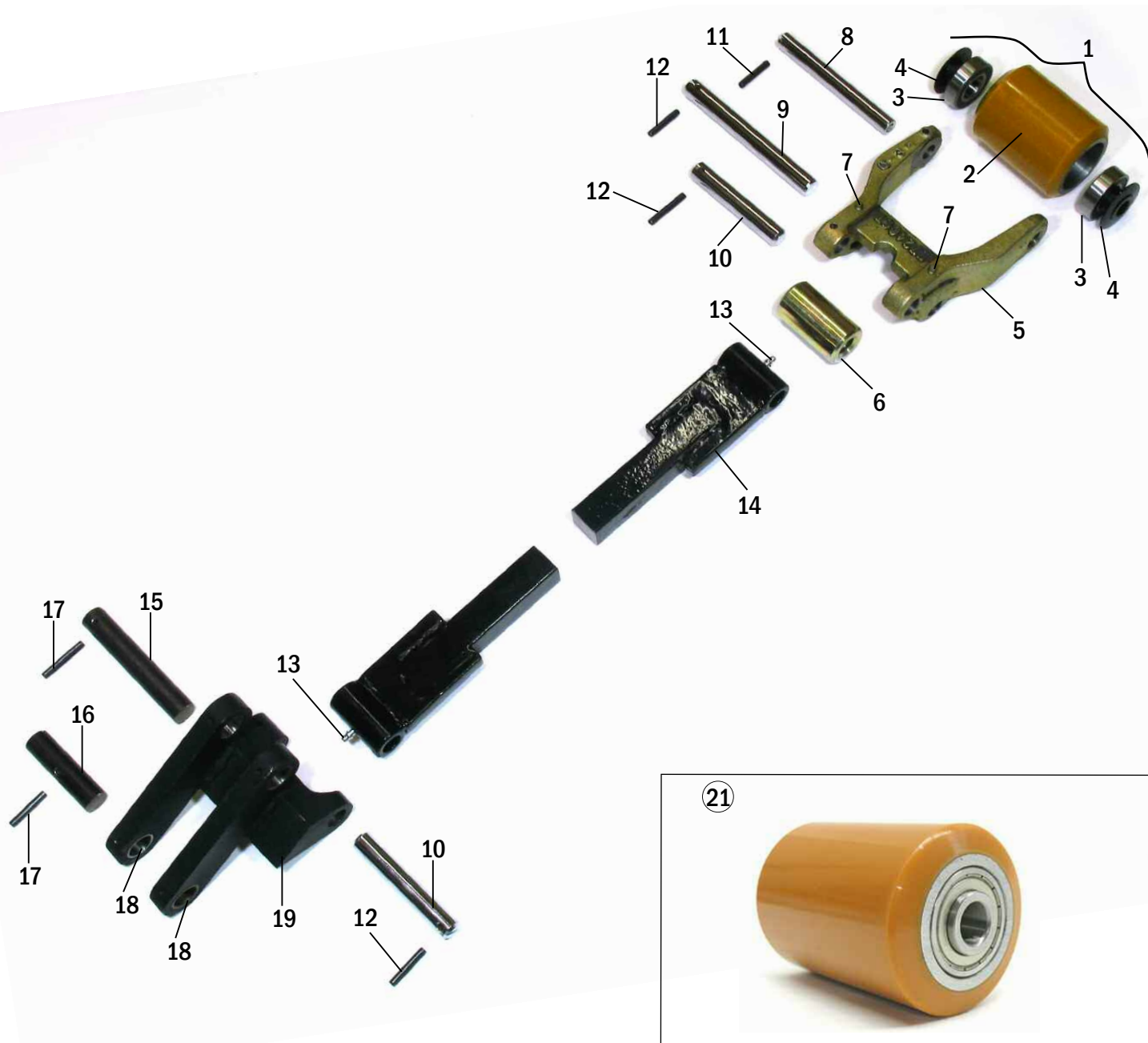

Frame & Undercarriage - Load Wheel & Link Linkage

Item	Part No.	Description	Application
1	HY 2046054-A1	Load wheel assembly, high load (95A)	
2	HY 2046054	Load wheel, high load	
3	HY 2046055	Wheel bearing	
4	HY 2046056	Bushing	
5	HY 2046053	Riser	
6	HY 2307475	Exit roller	
7	HY 2046058	Grease fitting	
8	HY 2046057	Load wheel axle, Corrosion resistant	
9	HY 2046263	Pivot pin, Corrosion resistant	
10	HY 2046264	Pivot pin, Corrosion resistant	
11	HY 2046059	Spiral pin	
12	HY 2050087	Spiral pin	
13	HY 2042833	Grease fitting	
14	HY 2046286	Push rod, 48" forks	
15	HY 2046260	Pivot pin	
16	HY 2046259	Pivot pin	
17	HY 2050088	Spiral pin	
18	HY 2307600	Bushing	
19	HY 2050086	Lower rear link (R.H.)	
20	HY 2050085	Lower rear link (L.H.) - not shown	
21	HY 2046054-A	Load wheel assembly, high load (95A)	
22	HY 2043251	Load wheel & riser assembly	
23	HY 800127595	Load wheel & axle assembly	

Frame & Undercarriage - Caster Assembly

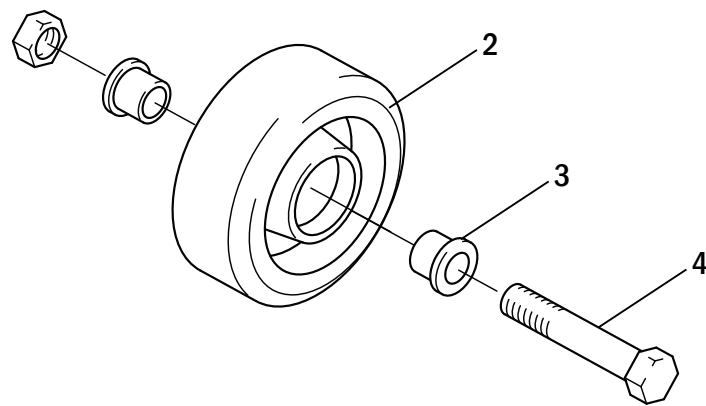
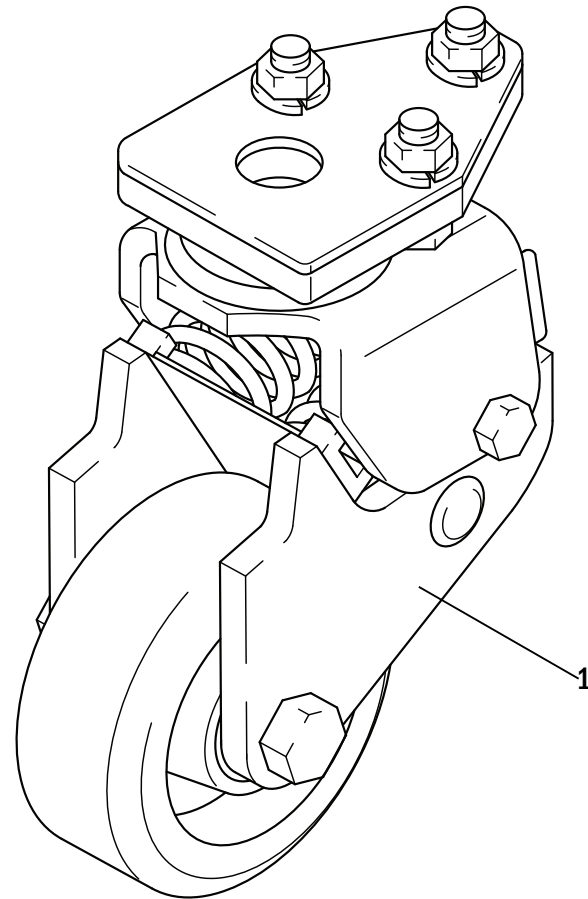

Frame & Undercarriage - Caster Assembly

Item	Part No.	Description	Application
1	HY 2044852	Caster assembly	
2	HY 2046537	Wheel assembly, Incl. bearings	
3	HY 2046842	Bushing	
4	HY 2013303	Axle, bolts and nuts	



800-462-2370

Fax 800-366-5939

www.SuperStoresService.com